

Acadia Corner T.V. Stand

Available Finishes:

# 465 00	Western Oak
# 465 11	Bungalow Oak
# 465 22	Manhattan Oak
# 465 47	Cherry Mist Maple
# 465 27	Autumn Maple
# 465 99	Merlot Maple
# 465 39	Chocolate Maple
# 465 51	Mascara Maple

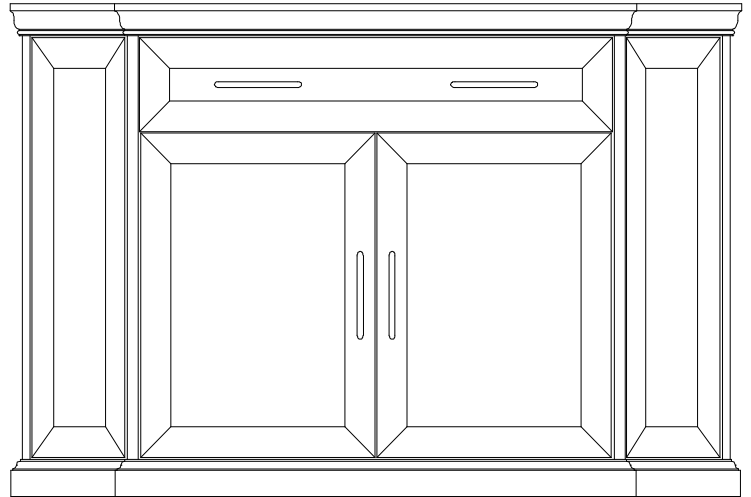

Design Features:

- **Wood Species:** - Solid 4/4 Maple used in frames and mouldings.
- Birch veneer used in top, bottom, and sides.
- **Lighting:** - N/A
- **Shelves:** - 1 adjustable/removable shelf in center
- 2 adjustable/removable shelves on each side
- **Joinery:** - Mortise and tenon door frames.
- **Glass:** - 3mm thick glass in doors.
- 5mm thick glass shelf, polished all around.
- **Hardware:** - Handle finished brass.
- **Carton Weight:** - 100 lbs.
- **Carton Volume:** - 22.6 cu ft
- **Height:** - 32-7/16" from floor to tallest point.
- **Features:** - Multi-functional media storage.
- Fits most 50" televisions, finished top.
- **Inner Dimensions :**
 - Side storage: 8-3/4"w x 8-1/4"d x 28"h
 - Center area: 31-1/4"w x 15"d x 20-7/8"h
 - Drawer: 29-1/2"w x 11-1/8"d x 5-1/8"h

Footprint/Floorplan:

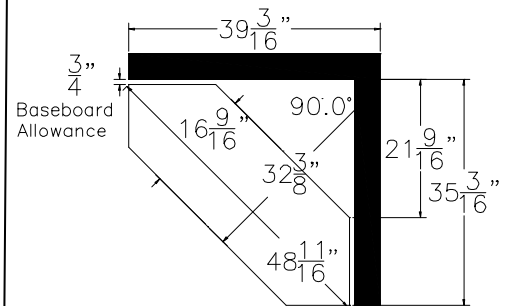

Glass Shelf Size:

